

Models: PF2005, PF2015, PF2025, PF2035, PF2045, PF2055, PF2085, PF2095, PF2125, PF2135, PF2155

For Sewage, Effluent, Grinder & Non-Clog Pumps

Features:

- **ENCLOSURE:** NEMA 4X weather resistant Poly enclosure with stainless door latches w/padlock hasp
- **CIRCUIT BREAKER:** For pump and control circuit
- **CONTACTOR:** IEC
- **OVERLOAD RELAY:** Bimetal type, ambient compensated
- **HEATER ELEMENT:** Class 10 quick trip, one heater for each phase
- **SWITCH:** Pump Hand-off-Auto
- **SWITCH:** External, Test/Normal/Silence with UV resistant sealing boot
- **LIGHT:** Green pump run
- **SUB PLATE:** Switch and light mounting
- **FUSES:** 1 Amp, Control circuit; 1 Amp, Alarm circuit
- **TRANSFORMER:** With primary & secondary fuse protection
- **ALTERNATOR:** Automatic
- **TERMINAL STRIP:** Box lugs for customer wiring & ground lugs
- **WIRING:** Color coded internal wiring
- **AUDIBLE ALARM:** Externally mounted 90 db @ 10 Ft. buzzer
- **ALARM LIGHT:** 360 degree red alarm light
- **SEAL LEAK SENSOR*:** Seal leak circuit with indicator light
- **TEMPERATURE SENSOR*:** Motor heat sensor circuit with indicator light
- **LEVEL CONTROL:** Includes Qty. 4, normally open, mechanical, pilot duty, narrow angle, 5 Amp @ 120/240 VAC, Floats with 15 Ft. 16/2, SJOW cords and external weight.

Built and Labeled to UL 508A standard with NEMA 4X rating. Consult factory for other available options. Some options may require an increase in the enclosure size.

WARNING: CANCER AND REPRODUCTIVE HARM-
WWW.P65WARNINGS.CA.GOV

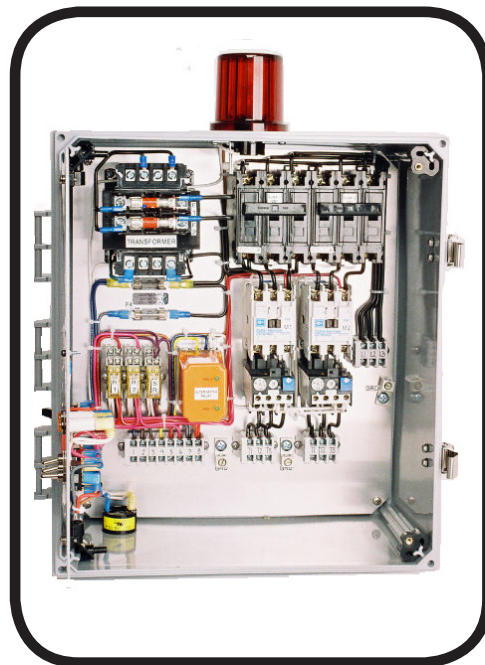

**Control Panel
Duplex, NEMA 4X
Three Phase,
460 Volt**



HP	VOLTS	MAX AMPS	PART NUMBER
1/2	460	0-11	PF2005-O
3/4, 1	460	0-11	PF2015-O
1.5, 2	460	0-11	PF2025-O
2.8, 3	460	0-11	PF2035-O
3	460	0-11	PF2035-OST
3.7	460	0-11	PF2045-O
4.5, 5	460	0-11	PF2055-O
4.2, 4.5, 4.8	460	0-11	PF2055-ST
4.5, 5	460	0-11	PF2055-OST
7.5	460	0-11	PF2085-ST
7.5	460	20	PF2085-OST-20
9	460	20	PF2095-ST-20
9	460	20	PF2095-OST-20
11.3, 12	460	20	PF2125-OST-20
13	460	20	PF2135-ST-20
15	460	20	PF2155-OST-20

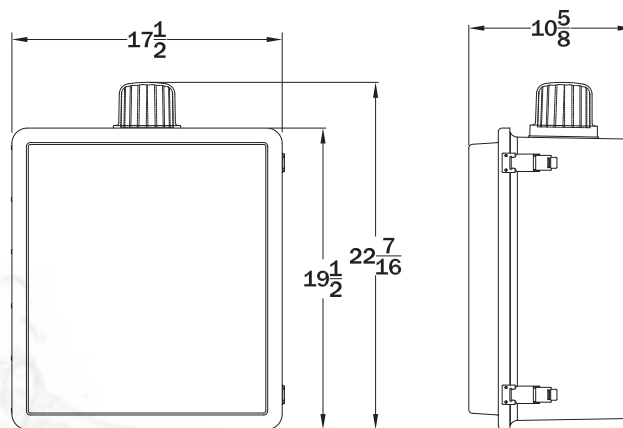

(*) ST = Seal Leak & Motor Thermal Overload Detection
C= Capacitor Start Components, O = Overload Protection



Power-Flo Pumps & Systems

a Power-Flo Technologies company

877-24PUMPS • fax: 516-812-6897 • www.powerflopumps.com

Accessories - Control Panels - Duplex - 460 Volt - 3Ph

Models: PF2005, PF2015, PF2025, PF2035, PF2045, PF2055, PF2085, PF2095, PF2125, PF2135, PF2155
For Sewage, Effluent, Grinder & Non-Clog Pumps

1/2 thru 2, 2.8, 3, 3.7, 4.2, 4.5, 4.8, 5, 7.5, 9,
 11.3, 12 & 13HP
Standard Panel Schematic

Standard Panel Layout

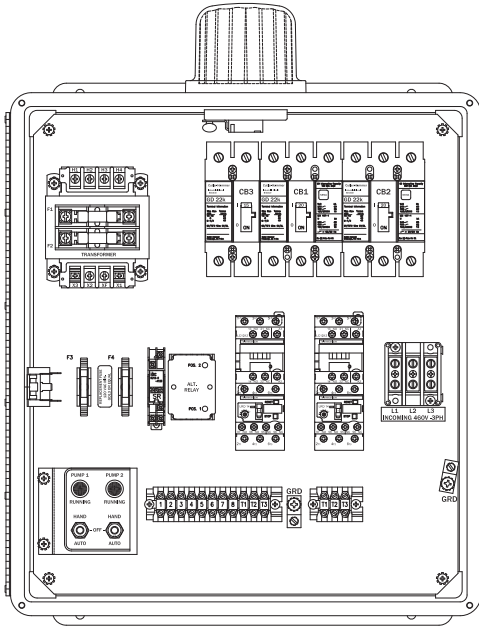
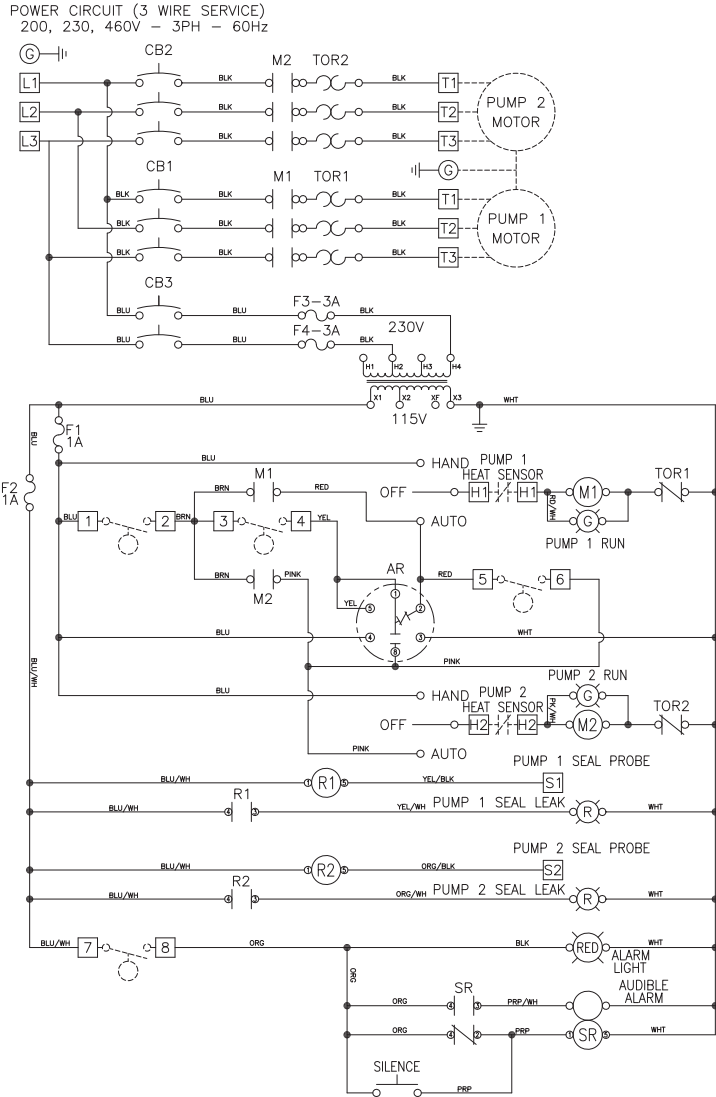

NOTES:

1. Panel shown with Seal Leak and Temperature sensors (ST)
2. Panels that are **NOT** indicated with (ST*) do not include Seal Leak and Temperature sensors

