

**Model: PFSPCPC5030721T10
PFSPCPC5030721T20**

Features:

General purpose pump for residential, light industrial and commercial sump applications

- **DISCHARGE:** 1-1/2" NPT Male, Vertical, 1-1/4" with Adapter
- **LIQUID TEMPERATURE:** 32°-77°F
- **MOTOR HOUSING:** Cast Iron.
- **IMPELLER:** Corrosion-resistant, reinforced Thermoplastic
- **PUMP BASE:** Cast Iron.
- **SHAFT:** Stainless Steel
- **HARDWARE:** Stainless steel
- **GASKET:** Rubber
- **SEAL:** Single mechanical, rubber and stainless steel
- **UPPER BEARING:** Single row, ball, oil lubricated
- **LOWER BEARING:** Single row, ball, oil lubricated
- **POWER CORD:** SJTW, 18AWG/3C Cord, with plug.
P/N: 10Ft. - PFL183062, 20Ft. - PFL181061
- **MOTOR:** Energy efficient Permanent Split Capacitor (PSC), Water Cooled, Class B insulation, Continuous duty (water depth must be at least 6" to prevent motor from overheating), Auto reset thermal overload protector, Circuit requirements 15 AMPS.
- **LEVEL CONTROL:** Wide Angle Tethered, Mechanical, Normally Open (N/O), Reinforced thermoplastic, SJOW 18AWG/2C, cord w/Piggy-back plug, On point - 14.6", Off point - 6.3"
P/N: 10Ft. - PFTFS10D1810P1 20Ft. - PFTFS10D1820P1
- **WARRANTY:** 3 year

 **WARNING: CANCER AND REPRODUCTIVE HARM-**
WWW.P65WARNINGS.CA.GOV



**Submersible Sump Pump
1-1/2" Discharge,
1/4" Spherical Solids
Wide Angle Tethered Float**



MODEL	HP	Hz	Volts/Ph	RPM	FL AMPS	Cord Length	Wt.
PFSPCPC5030721T10	1/2	60	115/1	3450	4.7	10 ft	21 lbs
PFSPCPC5030721T20	1/2	60	115/1	3450	4.7	20 ft	21.2 lbs

HEAD in Ft	0 Ft	5 Ft	10 Ft	15 Ft	20 Ft	25 Ft	Max Lift	Max Pressure
FLOW Gallon/Minute	72	65	58	52	42	28	30 Ft	13.2 psi
FLOW Gallon/Hour	4300	3900	3500	3100	2500	1700		



PF	TYPE U, SP, SW	Motor Housing P, C	Impeller Type P, C	Suction Plate Type P, C	Motor HP 25, 33, 50, 75, 1	30	50	Voltage 1 or 2	Float Switch Type M, F, T	Cord Length 10, 20
Power-Flo	U = Utility SP = Sump Pump SW = Sewage Pump	P = Plastic C = Cast Iron	P = Plastic C = Cast Iron	P = Plastic C = Cast Iron	25 = 1/4 HP 33 = 1/3 HP 50 = 1/2 HP 75 = 3/4 HP 1 = 1 HP	Shut Off Head (ft)	Max Flow (Gal)	1 = 115 V 2 = 230V	M = Manual F = Fixed Vertical T = Tethered	10 Ft 20 Ft

EXAMPLE: PFSPCPC3330501T10 - Power-Flo Pumps - Sump Pump - Cast Iron Motor Housing - Plastic Impeller - Cast Iron Suction Plate - 1/3HP - 30" Shut Off Head - 50GPM Max Flow - 115 Volt - Tethered Float - 10' Cord



Power-Flo Pumps & Systems

a Power-Flo Technologies company

877-24PUMPS • fax: 516-812-6897 • www.powerflopumps.com

Sump & Utility Pumps - 1/2HP - 3450RPM - Cast Iron

Sump & Utility Pumps - 1/2HP - 3450RPM - Cast Iron

**Model: PFSPCPC5030721T10
PFSPCPC5030721T20**

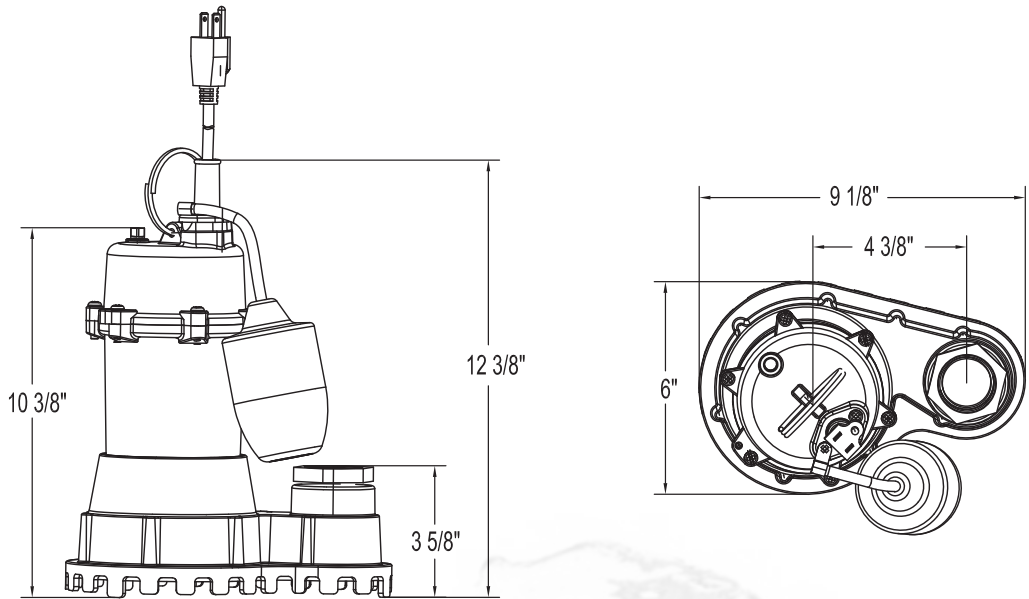
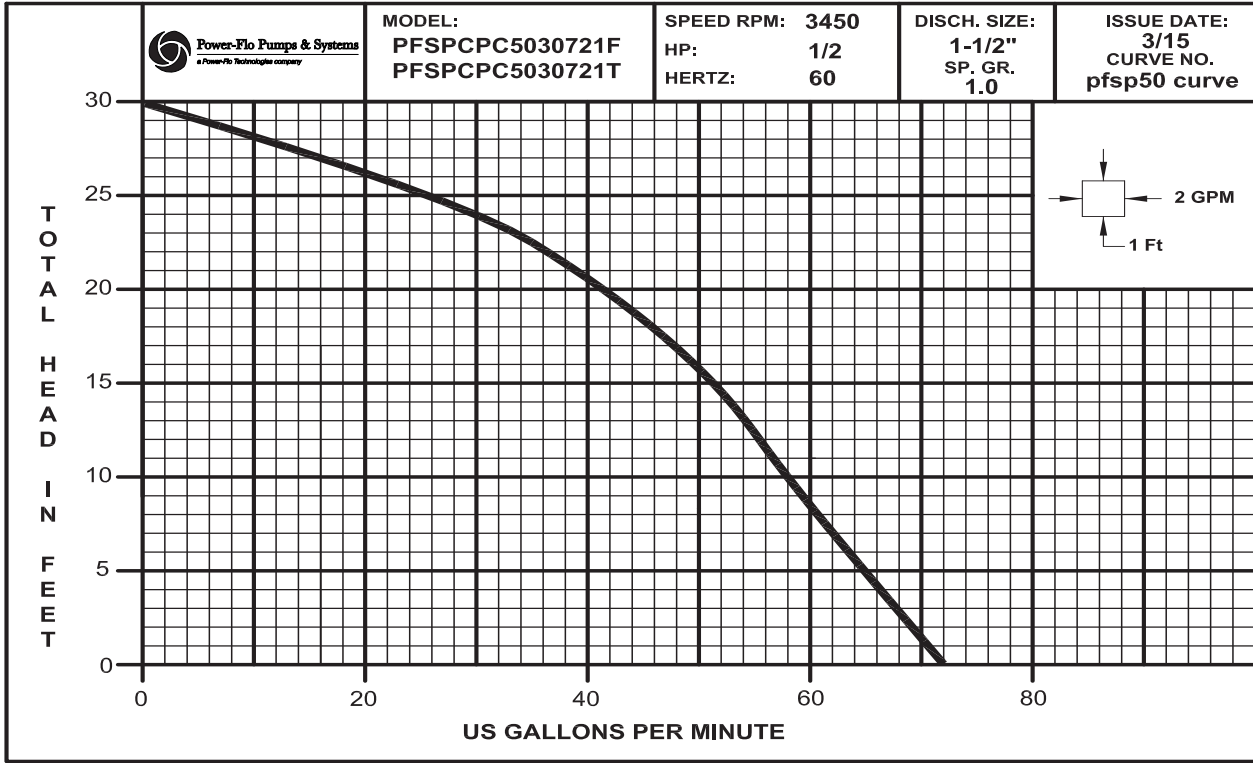

PF	TYPE U, SP, SW	Motor Housing P, C	Impeller Type P, C	Suction Plate Type P, C	Motor HP 25, 33, 50, 75, 1	30	50	Voltage 1 or 2	Float Switch Type M, F, T	Cord Length 10, 20
Power-Flo	U = Utility SP = Sump Pump SW = Sewage Pump	P = Plastic C = Cast Iron	P = Plastic C = Cast Iron	P = Plastic C = Cast Iron	25 = 1/4 HP 33 = 1/3 HP 50 = 1/2 HP 75 = 3/4 HP 1 = 1 HP	Shut Off Head (ft)	Max Flow (Gal)	1 = 115 V 2 = 230V	M = Manual F = Fixed Vertical T = Tethered	10 Ft 20 Ft

EXAMPLE: PFSPCPC3330501T10 - Power-Flo Pumps - Sump Pump - Cast Iron Motor Housing - Plastic Impeller - Cast Iron Suction Plate - 1/3HP - 30" Shut Off Head - 50GPM Max Flow - 115 Volt - Tethered Float - 10' Cord

