



**Power-Flo Technologies**

Power-Flo Pumps and Systems

# **PFG200-21**



**2 HP • 3450 RPM • 60 HZ**  
**Submersible Grinder Pump**



## Models: PFG200-21,PFG200-21P

### Features:

Designed to reduce domestic, commercial, institutional and light industrial sewage to a finely ground slurry.

- **DISCHARGE:** 1-1/4" NPT Vertical Bolt-on Flange
- **LIQUID TEMPERATURE:** 140°F Intermittent
- **MOTOR HOUSING, VOLUTE & SEAL PLATE:** Cast Iron, Class 30
- **IMPELLER:** 10-vane, Vortex with pump out vanes on back side, Dynamically balanced, ISO G6.3, Cast Iron
- **SHREDDING RING & CUTTER:** Stainless steel
- **SHAFT & HARDWARE:** Stainless steel
- **PAINT:** Industrial Grade Powder Coating
- **SQUARE RINGS:** Buna-N
- **SEAL:** Tandem Double Mechanical, in Oil Filled reservoir, SiC/SiC inboard, SIC/Carbon outboard.
- **UPPER BEARING:** Single row, ball, oil lubricated
- **INTERMEDIATE BEARING:** Single row, ball, oil lubricated
- **LOWER BEARING:** Sleeve, oil lubricated
- **POWER CORD:** 20 Ft. SJOW 14/3 Quick Change Cord with plug, Pressure Grommet for Sealing and Strain Relief
- **MOTOR:** Class B Insulation, Oil Filled, Squirrel cage induction
- **SINGLE PHASE:** Capacitor Start/Capacitor Run, Included. Includes overload protection in the motor.
- **LEVEL CONTROL:** PFG200-21P includes wide angle mechanical float, 20FT cord
- **WARRANTY:** 2 year



**WARNING:** CANCER AND REPRODUCTIVE HARM-  
WWW.P65WARNINGS.CA.GOV



**Automatic  
Submersible Grinder  
Pump 1-1/4"  
Discharge Dual Seal**



MODEL	HP	Hz	Volts/ Ph	RPM	Full Load Amps	Locked Rotor Amps	NEMA Start Code	Cord Type	Cord Size	Simplex Control	Duplex Control
PFG200-21	2	60	230/1	3450	15.0	53.0	H	SJOW	14/3	PF1021	PF2021
PFG200-21P	2	60	230/1	3450	15.0	53.8	H	SJOW	14/3	PF1023	PF2023

NOTE: Remove plug for use with control panel

**IMPORTANT! - DO NOT** introduced into any sewer, either directly, or through a kitchen waste disposal unit or toilet: *Seafood Shells, Aquarium Gravel, Cat Litter, Plastic Objects (toys, utensils, etc.), Sanitary Napkins or Tampons, Diapers, Rags, Disposable Wipes or Cloth, Medications, Flammable Material, Oil or Grease, Strong Chemicals, or Gasoline.*

These pumps are not approved for use in swimming pools, recreational water parks, or installations where human contact with pumped media is a common occurrence.

Not sure about which pump to choose or where to start? Simply scan our QR code to unlock our comprehensive manual, designed to guide you through the process of finding the perfect pump for your specific needs. Contact Power-Flo Pumps today.





# Power-Flo Pumps & Systems

a Power-Flo Technologies company

PFG200-21

3500RPM

2.0" MAX SOLIDS

Discharge

1.25"

Stages/Weight

1-stage / 95.0lbs (pump only)

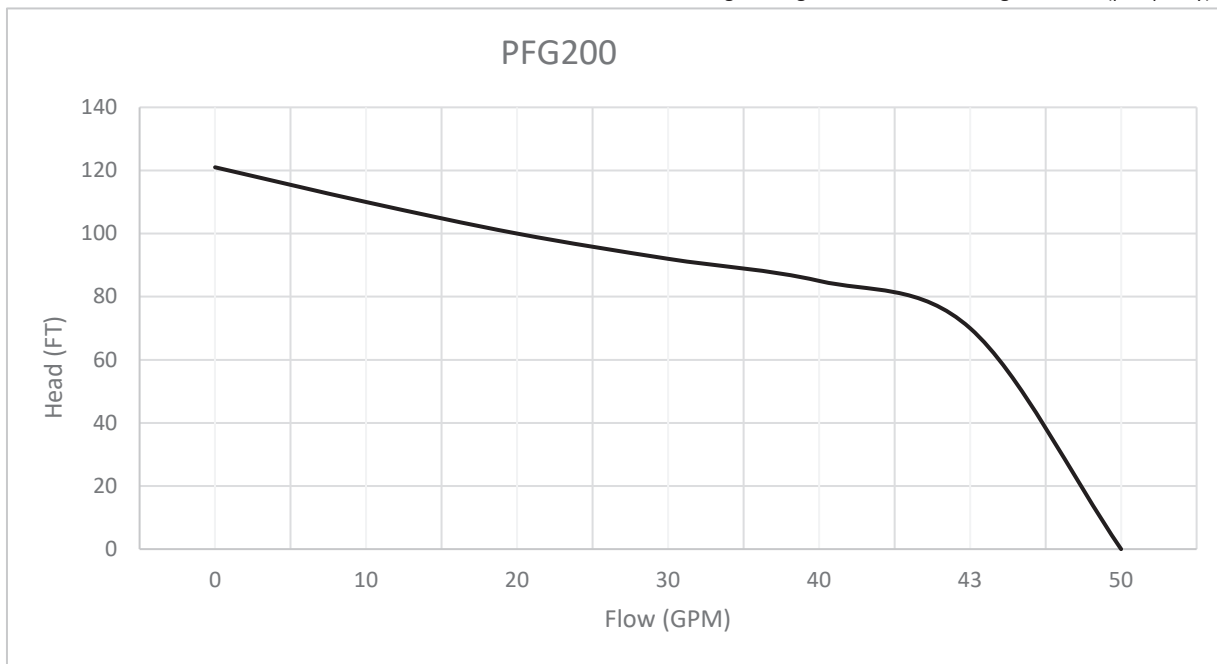



Model: PFG200-21

# OWNER'S MANUAL

## SUBMERSIBLE GRINDER PUMPS

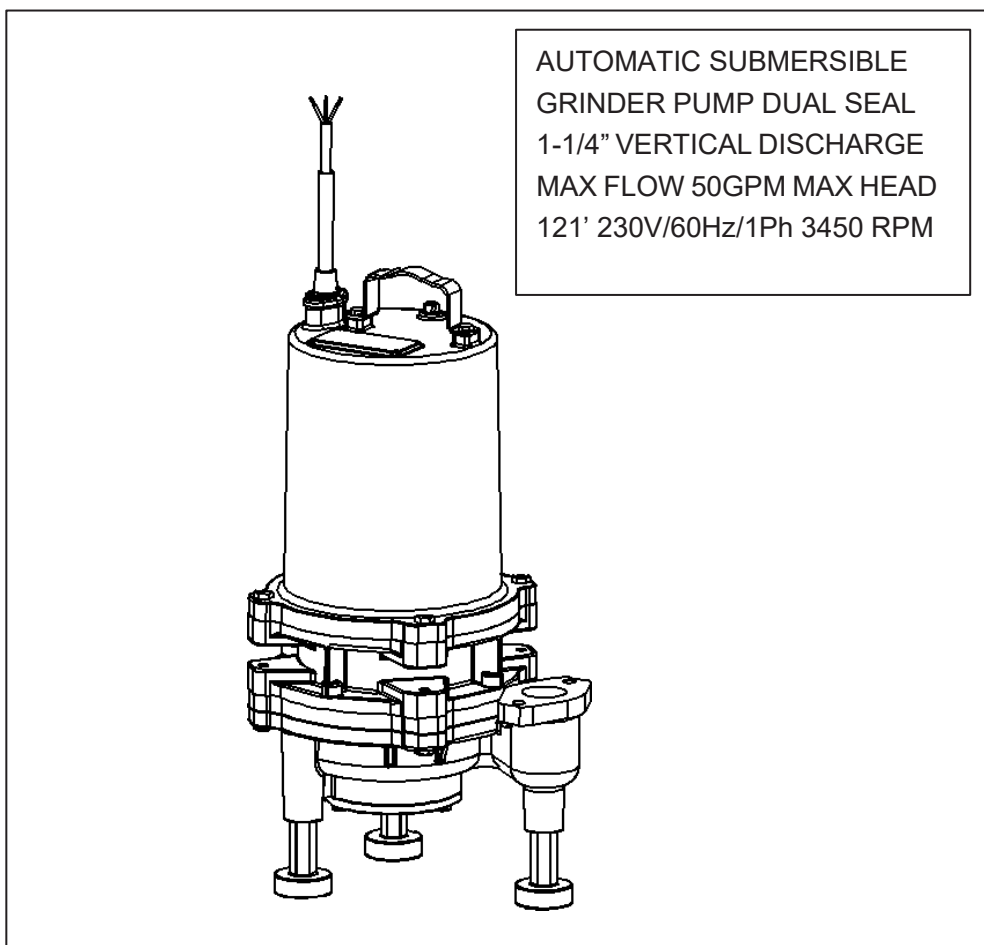



Questions, problems, missing parts? Before returning to the store call  
our Customer Service 8 a.m. - 6 p.m., EST, Monday-Friday

**877-24PUMPS**

# SAFETY INSTRUCTIONS

Before installation, read the following instructions carefully. Failure to follow instruction and Safety information could cause serious bodily injury, death and/or property damage. Each Power-flo pump is individually factory tested to insure proper performance. Closely following these instructions will eliminate potential operating problems, assuring years of trouble-free service.

 <b>Warning</b>	Potentially hazardous situation. Failure to follow the instructions could result in death or serious injury.
 <b>Caution</b>	Failure to follow the instructions given could result in minor injury, or damage to the pump.

 <b>Warning</b>	All returned Products must be Cleaned, sanitized, Or decontaminated Prior to shipment, to insure employees will not be exposed to health hazards in handling said material. All applicable laws and regulations shall apply.
	Bronze/brass fitted pumps may contain levels higher than considered safe for potable water systems. Government agencies have determined that leaded copper alloys should not be used in potable water applications.
	Installation, wiring, and junction connections must be in accordance with the National Electric Code and all applicable state and local codes. Requirements may vary depending on usage and location.
	Installation and servicing is to be conducted by qualified personnel only.
	Rotating machinery, Amputation or severe lacerations can result. Keep clear of suction and discharge openings. Do not insert fingers in pump with power connected.
	Always wear eye protection when working on pumps. Do not wear loose clothing that may become entangled in moving parts.
	Before lifting the pump, check its weight and shape with reference to the outline drawing and catalogs for safe work. The pump could fall, exposing personnel to danger.
	Perform wiring work correctly as specified by electrical equipment technical standards and internal wiring codes. Incorrect wiring could result in electric shock and fires.
	Hazardous Voltage can Shock, burn or cause death. This pump is not intended for use in swimming pools or water installations where human contact with pumped fluid. Pumps when used as a decorative water fountain pump MUST be used in circuit protected by a Ground Fault Interrupter.
	Risk of electric shock. To reduce risk of electric shock, always disconnect pump from power source before handling. Lock out power & tag.
	Pumps build up heat and pressure during operation. Allow time for pumps to cool before handling or servicing.
	Do not lift, carry or hang pump by the electrical cables. Damage to the electrical cables can cause shock, burnes or death. Never handle connected power cords with wet hands. Use appropriate lifting device.
	Failure to permanently ground the pump, motor and controls before connecting to power can cause shock, burns or death.
These pumps are NOT to be installed in locations classified as hazardous in accordance with the National Electric Code, ANSI/NFPA 70.	



	Do not use these pumps in water over 140°F. Do not exceed manufacturer's recommended maximum performance, as this could cause the motor to overheat.
	Sump and sewage pumps often handle materials which could cause illness or disease. Wear adequate protective clothing when working on a used pump or piping. Never enter a basin after it has been used.
	Do not run the pump in empty operation in air. Doing so could cause insulation deterioration, resulting in electric shock or leakage.
	Always turn the power switch OFF before inspecting or repairing the pump. Not doing so could result in the pump starting up suddenly in auto operation, exposing personnel to danger.
	If the pump is to be out of use for a long time, turn off the power. If the power is left on and insulation deteriorates, electric shock, electrical leakage, or fire could result.

 <b>Caution</b>	If you have purchased a standard pump, refer to the standard specifications shown below. The optional specifications indicate changes made to some pumps to meet the needs of some customers. Be sure not to operate your pump outside of the ranges shown in the applicable specifications.
	Do not use the pump for food-related operation.
	Do not use the pump in life raising facilities (fish farm, preserve, and aquarium, etc.).
	Do not use the pump for critical facilities (computer cooling equipment and freezer cooling system, etc.).
	Do not use the pump with an inverter.
	Before operating the pump, perform flushing sufficiently, depending on facilities where the pump is used, and confirm that no foreign substance exists. Insufficient flushing could cause foreign substances, including cutting oil used in the pump manufacturing, mold release agents, and others, to be contained in the liquid handled.
	Do not use the pump for liquids other than water, such as oil, seawater, and organic solvents. The pump could fail, causing electric shock or leakage.
	This pump serves as a submersible pump for facility drainage. Do not run the pump continuously for a long time or at a too high frequency of start-stop operations. Otherwise leakage from the mechanical seal could lead to a failure of the pump in a short period.
	To prevent an accident if the pump stops running or an abnormality occurs, immediately turn off the power switch.
	Please replace a consumable part periodically. Do not use the pump with the depleted or worn part. It could result in leaking water or other critical damage.
Check that all connection screws of the conductive part are properly tightened. Loosen screw could result in heat generation, damage or burn out.	

**IMPORTANT!**

Prior to installation, record Model Number, MFG Date, Amps, Voltage, Phase and HP, from pump name plate for future reference. Also record the Voltage and Current Readings at Start up:

# SPECIFICATIONS

## PUMP

DISCHARGE	1-1/4" NPT Vertical, Bolt-on Flange
LIQUID TEMPERATURE	140°F Intermittent
VOLUTE	Cast Iron, Class 30
MOTOR HOUSING	Cast Iron, Class 30
SEAL PLATE	Cast Iron, Class 30
IMPELLER	10 Vane, Vortex, Cast Iron, Class 30
SHREDDING RING	Alloy Steel
CUTTER	Alloy Steel
SHAFT	Stainless Steel
SEAL	Seal Face: SiC/SiC(Pump liquid side) SiC /Carbon(Motor side)
UPPER BEARING	Single row, Ball, Oil Lubricated
LOWER BEARING	Single row, Ball, Oil Lubricated
MOTOR	Oil Filled, Squirrel Cage Induction, Class B Insulation
SINGLE PHASE	Capacitor Start/Capacitor Run. Includes overload protection in the motor.

**NOTE:** Consult factory before making modifications as they may effect CSA listing.

**Description**

Designed to reduce domestic, commercial, institutional and light industrial sewage to a finely ground slurry.

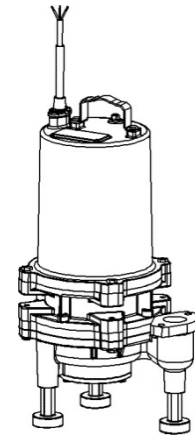

# SPECIFICATIONS

MODEL	HP	Hz	Volts	RPM	Full Load Amps	Locked Rotor Amps	NEMA Start Code	Cord Type	Cord Size
PFG200-21	2	60	230	3450	15.0	62.0	B	SJOW	14/3



# DIMENSIONS

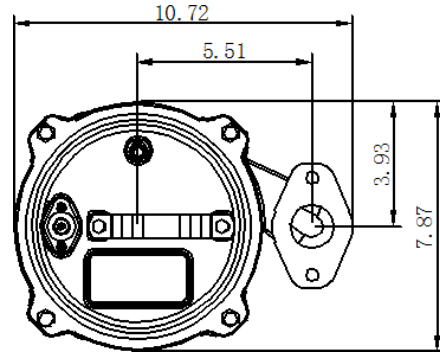
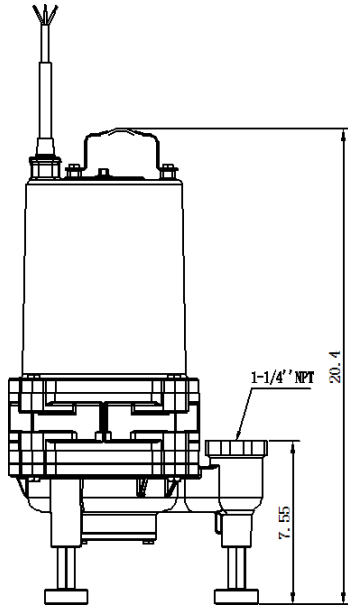

**IMPORTANT!** - Pump Suction **MUST** be a minimum of 4" from basin floor with use of legs, stand or slide rail system.

# RECEIVING & INSTALLATION

## Receiving Inspection

Upon receiving the pump, it should be inspected for damage or shortages. If damage has occurred, file a claim immediately with the company that delivered the pump. If the manual is removed from the packaging, do not lose or misplace.

## Storage

Any product that is stored for a period longer than six (6) months from the date of purchase should be bench tested prior to installation. A bench test consists of, checking the impeller to assure it is free turning and a run test to assure the motor (and switch if provided) operate properly. Do not pump out of liquid.

## Controls

The grinder pump requires a separate approved pump control device or panel for automatic operation. A junction box and float switches for water level control are available from Power-flo Pumps.

## Location

The grinder pump is designed to fit in basin or wet well by using a slide rail system (with legs removed) or by resting on floor of basin with legs attached.

## Submergence

The pump should always be operated in the submerged condition. The minimum sump liquid level should never be less than above the pump's volute (See Figure 1).

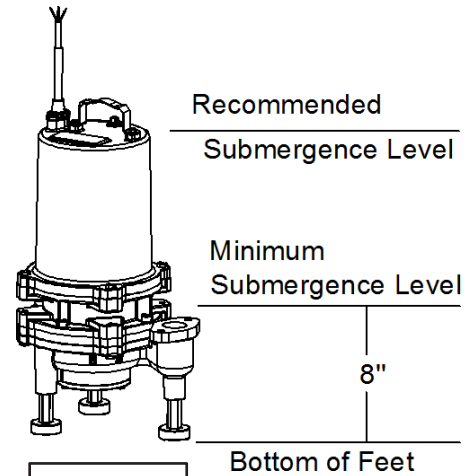

Figure 1

## RECEIVING & INSTALLATION

### Installation

There are several methods of installing grinder pumps. See contract plans and/ or specification: A slide rail in a package system or concrete wet well is the most common, which allows the pump(s) to be installed or removed without requiring personnel to enter the wet well.

The sump or basin shall be sealed and vented in accordance with local plumbing codes. This pump is designed to pump grinder or wastewater, nonexplosive and noncorrosive liquids and shall NOT be installed in locations classified as hazardous in accordance with the National Electrical Code (NEC) ANSI/NFPA 70 or Canadian Electric Code (CEC). The pump should never be installed in a trench, ditch, or hole with a dirt bottom. The legs will sink into the dirt and the suction will become plugged.

The installation should be at a sufficient depth to ensure that all plumbing is below the frost line. If this is not feasible, remove the check valve and size the basin to accommodate the additional backflow volume.

### Discharge Piping

Discharge piping should be as short as possible and sized no smaller than the pump discharge. Do not reduce the discharge pipe size below that which is provided on the pump. Both a check valve and a shut-off valve are recommended for each pump. The check valve is used to prevent backflow into the sump. The shut-off valve is used to manually stop system flow during pump servicing.

### Liquid Level Controls

The level control(s) should be mounted on the discharge piping, a cable rack or float pole. The level control should have adequate clearance so it cannot hang up in its swing and that the pump is completely submerged when the level control is in the "Off" mode. By adjusting the cord tether the control level can be changed. One cycle of operation should be observed, so that any potential problems can be corrected. It is recommended that the level control float should be set to insure that the liquid in the sump never drops below the top of the motor housing or a minimum level of 10 inches above the basin floor.

### Electrical Connections

Power cable - The power cable mounted to the pump must not be modified in any way except for shortening to a specific application. Any splice between the pump and the control panel must be made in accordance with the electric codes. It is recommended that a junction box **DO NOT USE THE POWER CABLE TO LIFT PUMP.**

Always rely upon a Certified Electrician for installation.

Incoming Power Configurations-Incoming voltage must match the control panel voltage. Power cord: CSA Certified/ UL recognized, Min NO.14/3 ,type SJOW or better.

### Thermal Protection:

A motor thermal protector is embedded in the motor windings and will detect excessive heat in the event an overload condition occurs. The thermal protector will trip when the windings become too hot and will automatically reset when the pump motor cools to a safe temperature. In the event of an over temperature, the source of this condition should be determined and repaired immediately.

**WARNING! - DO NOT LET THE PUMP CYCLE OR RUN IF AN OVERLOAD CONDITION OCCURS!**



## INSTALLATION & SERVICE

### Pre-Operation

1. Check Voltage and Phase Compare the voltage and phase information stamped on the pump name plate.
2. Check Pump Rotation - Improper motor rotation can result in poor pump performance and can damage the motor and/or pump. Incorrect rotation for Single-Phase pumps is unlikely. If the rotation is incorrect contact factory.
3. Name Plate - Record the information from the pump name plate to drawing in front of manual for future reference.
4. Insulation Test - An insulation (megger) test should be performed on the motor. Before the pump is put into service. The resistance values (ohms) as well as the voltage (volts) and current (amps) should be recorded.
5. Pump-Down Test - Be sure pump has been properly wired, lowered into the basin, sump or lift station, check the system by filling with liquid and allowing the pump to operate through its pumping cycle. The time needed to empty the system, or pump-down time along with the volume of water, should be recorded.

### Maintenance

No lubrication or maintenance is required. Perform the following checks when pump is removed from operation or when pump performance deteriorates:

- a). Inspect motor chamber for oil level and contamination.
- b). Inspect impeller and body for excessive build-up or clogging.
- c). Inspect motor and bearings.
- d). Inspect seal for wear or leakage.

### Servicing

**NOTE:** Item numbers in ( ) refer to Figures 4&5.

Cooling Oil - Anytime the pump is removed from operation, the cooling oil in the motor housing should be checked visually for oil level and contamination. To check oil, set unit upright. Remove pipe plug (40) from housing (31). With a flashlight, visually inspect the oil in the housing (31) to make sure it is clean and clear, light amber in color and free from suspended particles. Milky white oil indicates the presence of water. Oil level should be just above the motor when pump is in vertical position.

### Oil Testing

- Drain oil into a clean, dry container by placing pump on it's side, remove pipe plug (40), from housing (31). .  
Check oil for contamination using an oil tester with a range to 30 Kilovolts breakdown.
- If oil is found to be clean and uncontaminated (measuring above 15 KV. breakdown), refill the housing.
- If oil is found to be dirty or contaminated (or measures below 15 KV. breakdown), the pump must be carefully inspected for leaks at the shaft seal, cable assembly and pipe plug, before refilling with oil. To locate the leak, perform a pressure test. After leak is repaired, dispose of old oil properly, and refill with new oil.

**Pressure Test (If oil has been drained)**, Remove pipe plug (40) from housing (31). Apply pipe sealant to pressure gauge assembly and tighten into hole. Pressurize motor housing to 10 P.S.I. Use soap solution around the sealed areas and inspect joints for "air bubbles".

If, after five minutes, the pressure is still holding constant, and no "bubbles" are observed, slowly bleed the pressure and remove the gauge assembly. Replace oil. Leek must be located and repaired if pressure does not hold.

**Pressure Test (If oil has NOT been drained)** - Oil should be at normal level. Remove pipe plug (40) from housing (31). Apply pipe sealant to pressure gauge assembly and tighten into hole. Pressurize motor housing to 10 P.S.I. Use soap solution around the sealed areas above the oil level and inspect joints for "air bubbles". For sealed areas below oil level, leaks will seep oil. If, after five minutes, the pressure is still holding constant, and no "bubbles"/ oil seepage is observed, slowly bleed the pressure and remove the gauge assembly. Replace oil. Leek must be located and repaired if pressure does not hold.

**SERVICE**

⚠	<b>Caution</b>	Pressure builds up extremely fast, increase pressure by "TAPPING" air nozzle. Too much pressure will damage seal. <b>DO NOT exceed 10 P.S.I.</b>	!
---	----------------	--	---

## Oil Replacement

**Motor Housing** - Drain all oil (if not already done so) from motor housing and dispose of properly per Local and Environmental Standards.

Set pump upright and refill with new cooling oil, see "Cooling Oil" chart. Fill to just above motor as an air space must remain in the top of the motor housing to compensate for oil expansion. Apply pipe thread compound to threads of pipe plug (40) then assemble to motor housing (31).

**DO NOT** overfill oil. Over filling of housing with oil can create excessive and dangerous hydraulic pressure which can destroy the pump and create a hazard. Overfilling oil voids warranty.

**WARNING!** - Before any service work is done, disconnect and lock out electrical power to pump.

## Disassembly

**Cutter** - Lay pump on its side, Use a flathead screwdriver to hold the shaft, then turn the radial cutter (20) counter-clockwise to release the radial cutter (20).

**CAUTION!** - Cutter edges are very **SHARP**. Cutter must be removed before removing volute.

**Volute** – Remove cap screw (19) then remove volute (21) and volute washer (26) from pump.

**Shredding Ring** – Remove cap screw (24), then to replace or reverse the shredding ring (22) press out using an arbor press.

**Impeller** - Remove impeller (25) by turning counter-clockwise while holding the motor shaft stationary with a screwdriver.

**NOTE:** Seal spring is relaxed with impeller removed, some oil may seep from seal cavity. Do Not store pump without impeller in place.

**Seal Plate** –Remove oil plug (27), then drain all oil from seal plate (17).Remove cap screws (18) from seal plate (17).

Remove seal plate (17) and O-ring (15) from bearing bracket (16). With flat screwdriver, press out seal (28) stationary member. Inspect O-ring (15) for cuts or abrasions.

**Seal** - Handle seal parts with care. Remove seal (28) spring and rotating member from shaft. Examine all seal parts.

Inspect contact faces for signs of uneven wear tracks on stationary, chips and scratches on either seal face. **DO NOT** interchange seal components, replace the entire shaft seal (28). (See Figure 2)

**IMPORTANT!** - All parts must be clean before reassembly. Handle seal parts with extreme care. **DO NOT** damage lapped surfaces.

**Power Cable**-Remove pipe plug (40) and drain oil if not already done so. Position pump upright using blocks or pvc pipe to avoid resting pump on the shaft. Remove cap screws (2) and power core plate (3) from cable assembly (1) and remove cable assemble (1) by pulling straight up.

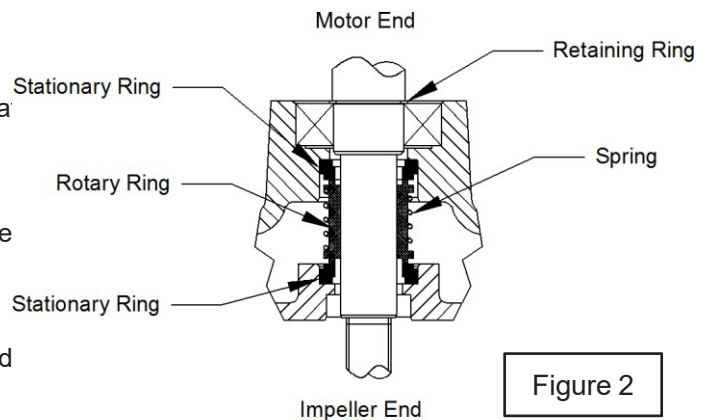

Figure 2

Double-end Mechanical Seal Structure



# Reassembly

**Mechanical Seal** - Clean and oil seal cavity in bearing bracket (16). Lightly oil (Do not use grease) outer surface of stationary member. Press seal's (28) stationary member firmly into bearing bracket (16), using a seal tool or pipe.

Nothing should come in contact with the seal face except the seal tool. Be sure the stationary is in straight. Place seal's (28) rotary ring and spring over shaft until seated on shaft shoulder. Slide a bullet tool over rotor shaft threads. Lightly oil (**Do not use grease**) shaft, bullet, and inner surface of bellows on rotating member, with finished end away from motor, slide rotating member over bullet and onto shaft until it engages spring.

Make sure spring is seated in retaining ring and spring is lined up on rotating member and not cocked or resting on bellows tail. (See Figure 2)

**IMPORTANT! Do not hammer on the seal pusher. It will damage the seal face.**

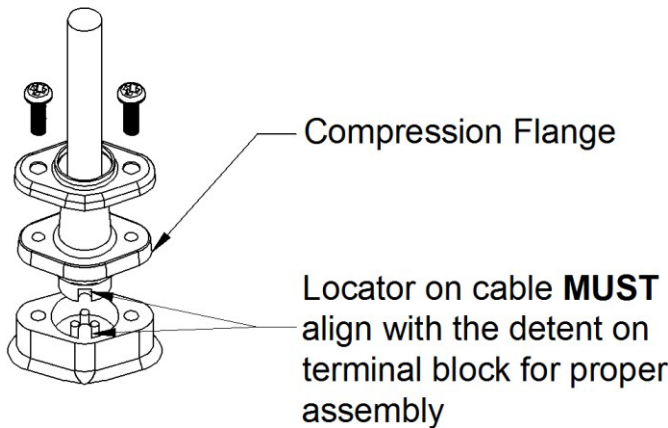

**Power Cable Connection** - Check power cord (1) for cracks or damage and replace if required. Insert female end of cord plug into housing bore aligning timing mark with hole in terminal block, see Figure (3). Compress cord plug with compression flange by tightening cap screws (2) with power cord plate (3) into the housing (31). Torque to 132 in-lbs

**Seal Plate** -Place seal plate (17) and O-ring (15) on bearing bracket (16). Place cap screw (18) on seal plate (17). Refill with new oil into seal plate (17). Place oil plug on seal plate (17).

Power Cable Connection

Figure 3

**Impeller** - Place impeller (25) on motor shaft, with machined step fitting inside the inside diameter of seal spring, by turning clockwise while holding shaft stationary with screwdriver.

**Shredding Ring** - Install shredding ring (22) into volute with the use of an arbor press. Place cap screw(24) on shredding ring(22).

**Volute**- Place volute (21) and volute washer (26) on seal plate (17). Place cap screw (19) and torque evenly to 11 ft/lbs.

**Note: Discharge must line up with notch in motor housing.**

**Cutter** - Screw radial cutter (20) onto shaft, turning it clockwise while holding the shaft stationary with a screwdriver. The radial cutter (20) should be flush with shredding ring (22), on suction side to within ± 0.020.

# PUMP WIRING SCHEMATICS

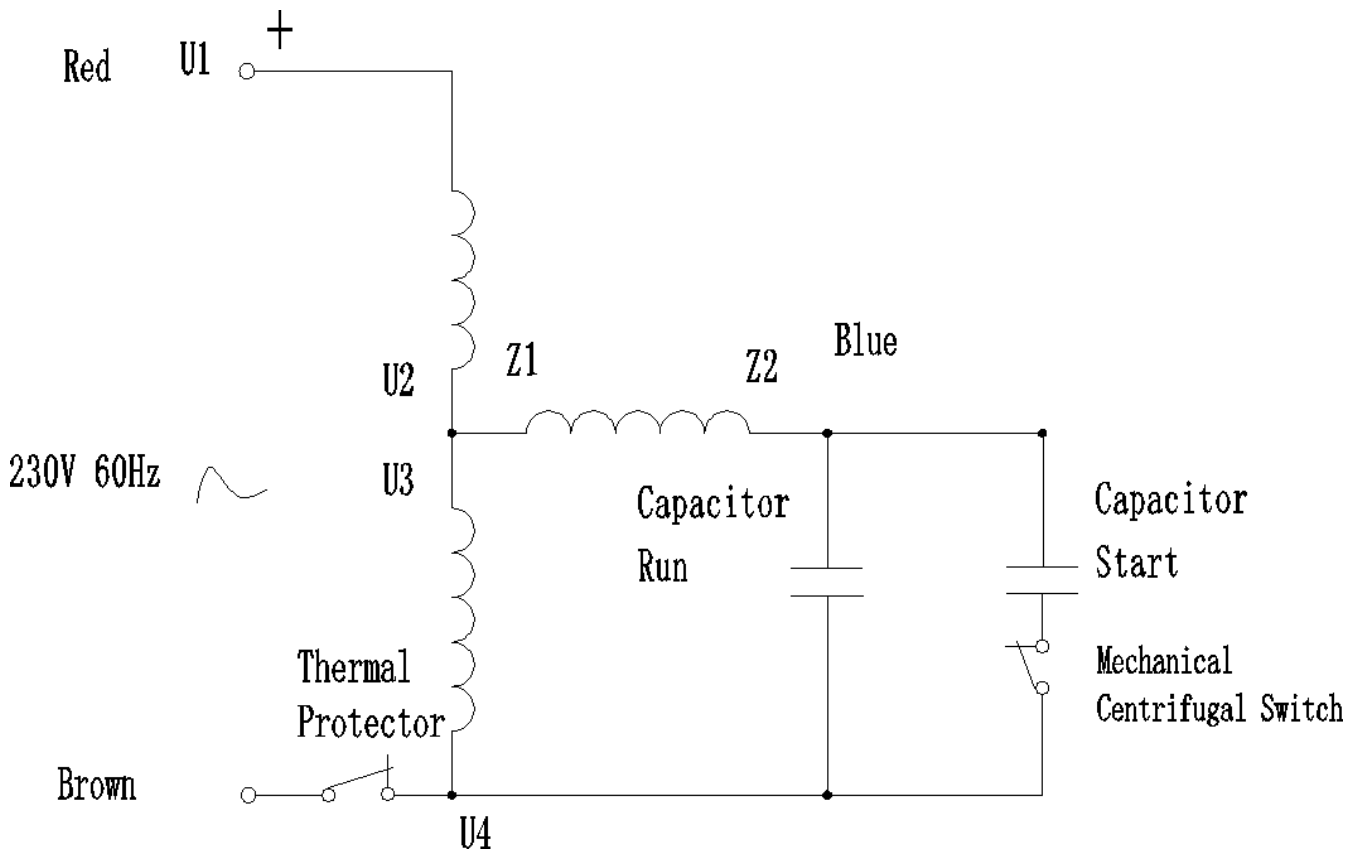



# REPAIR PARTS

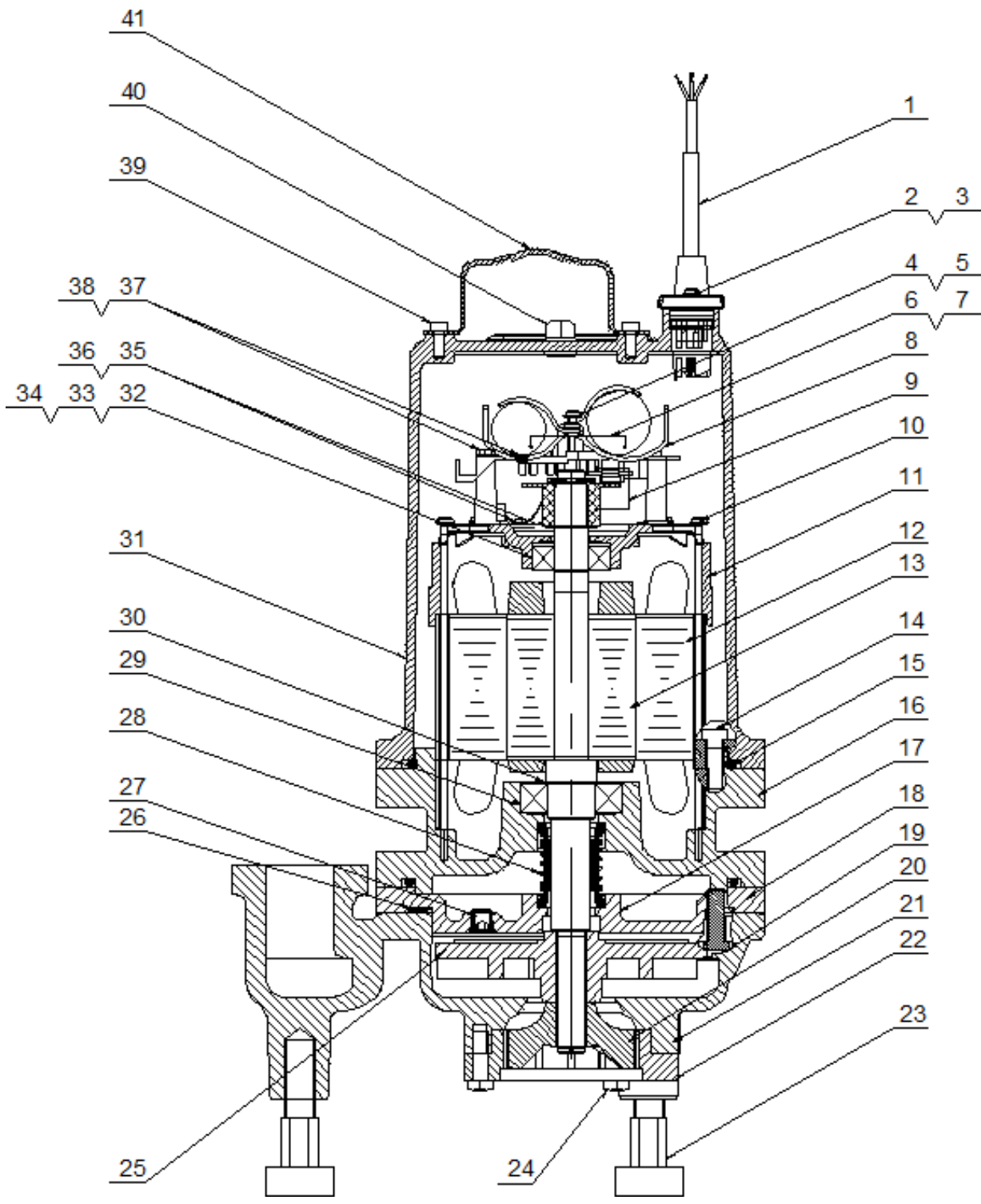

Figure 4

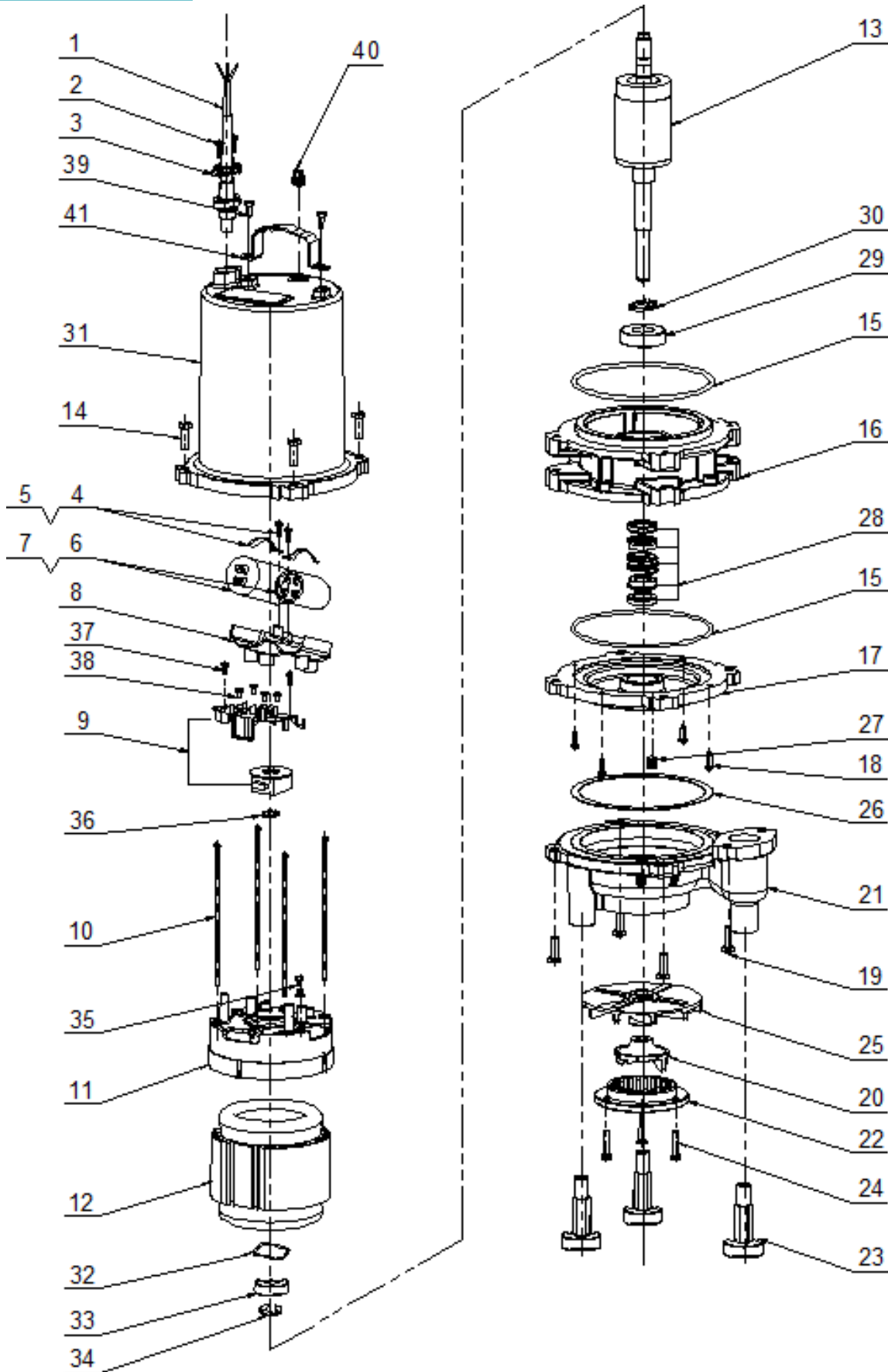



Figure 5



Ref.No.	Name	DESC	Qty
1	Power Cord (P/N: PF599020326)	14AWG/230V,20ft,SJOW	1
2	Cap Screw (P/N: PF401010031)	M5*15,Stainless	2
3	Power Cord Plate (P/N: PF103020019)	T0.8,Stainless	1
4	Capacitor Clamp		2
5	Cap Screw	ST4.2*16,Stainless	2
6	Capacitor	20UF,450VAC	1
7	Capacitor	150UF,330VAC	1
8	Capacitor Container		1
9	Mechanical Centrifugal Switch	L17-202/2S-A1	1
10	Bolt	M4*170	4
11	Upper Bracket	ZL102	1
12	Stator		1
13	Rotor		1
14	Cap Screw	M8*30,Stainless	4
15	O-ring (P/N: PF102010069)	D155*d5.3	2
16	Bearing Bracket		1
17	Seal Plate		1
18	Cap Screw	M5*20,Stainless	4
19	Cap Screw	M8*40,Stainless	4
20	Radial Cutter (P/N: PF103010030)		1
21	Volute		1
22	Shredding Ring (P/N: PF1030110029)		1
23	Pump Leg		3
24	Cap Screw	M6*30,Stainless	3
25	Impeller (P/N: PF599020100)		1
26	Volute Washer (P/N: PF102010117)	ϕ 166* ϕ 148*2,NBR	1
27	Oil Plug	NPT1/8"	1
28	Mechanical Seal (P/N: PF107010043)		1
29	Bearing	6205ZZ	1
30	Retaining Ring		1
31	Housing		1
32	Wave Washer		1
33	Bearing	6203ZZ	1
34	Retaining Ring		1
35	Cap Screw	M4*8	1
36	Retaining Ring		1
37	Cap Screw	M4*10(Hex)	2
38	Cap Screw	M4*10(Plus)	4
39	Cap Screw	UNF3/8"-24,Stainless	2
40	Pipe Plug Counter Sunk	NPT1/4"	1
41	Handle	Stainless	1

# TROUBLE SHOOTING CHART

 <b>Risk of electric shock. Always disconnect the pump from the power source before handling inspections or repairs.</b>		
Symptom	Possible Cause (s)	Corrective Action
Pump will not run	Blown fuse or other interruption of power; improper voltage.  Switch is unable to move to the “turn ON” position due to interference with the side of basin or other obstruction  Insufficient liquid level  Defective level control	Check that the unit is securely plugged in. Have an electrician check all wiring for proper connections and adequate voltage and capacity.  Position the pump or switch so that it has adequate clearance for free operation.  Make sure the liquid level is allowed to rise enough to activate level control(s). Remove and replace level controls
Pump will not turn off	Discharge is blocked or restricted  Check valve is stuck closed or installed backwards  Gate or ball valve is closed  Total lift is beyond pump’s capability  Pump impeller is jammed or volute casing is plugged	Check the discharge line for foreign material, including ice if discharge line passes through or into cold areas  Remove check valve(s) and examine for freedom of operation and proper installation  Open gate or ball valve  Try to route piping to a lower level. If not possible, a larger pump may be required. Consult the factory  Disconnect unit electrically. Remove the pump from the basin. Detach the pump base and clean the area around the impeller. Rotate impeller by hand. Reassemble and reinstall
Pump will not turn off	Level control (s) unable to move to the “turn OFF” position due to interference with the side of basin or other obstacle  Defective level control	Position the pump or level control so that it has adequate clearance for free operation  Remove and replace level control
Pump runs periodically when fixtures are not in use	Check valve is stuck open or is leaking  Fixtures are leaking	Remove check valve(s) and examine for freedom of operation and proper installation  Repair fixtures as required to eliminate leakage
Pump operates noisily	Debris in the impeller cavity  Damaged impeller  Worn bearings  Piping attachments to building are too rigid	Remove the pump from the basin. Detach the pump base and clean the area around the impeller. Reassemble and reinstall  Consult the factory for information regarding replacement of impeller  Return pump to the factory or authorized repair station for repair  Replace a portion of the discharge line with rubber hose or connector

**NOTE:** Power-flo Pumps assumes no responsibility for damage or injury due to disassembly in the field. Disassembly of the pumps or supplied accessories other than at Power-flo Pumps or its authorized service centers, automatically voids warranty.



## LIMITED WARRANTY

Manufacturer warrants, to the immediate purchaser and subsequent initial owner during the warranty period, every new pump to be free from defects in material and workmanship under normal use and service, when properly used and maintained, for a period of thirty six (36) months from date of manufacture or twenty four (24) months from date of installation (which ever comes first). Failure due to wear due to excessive abrasives is not covered. The initial owner is the purchaser who first uses the pump after its initial installation, or for non-permanent installation, the first owner who uses the pump. The date of installation shall be determined by a dated sales receipt noting the model and serial number of the pump. The dated sales receipt must accompany the returned pump. Product will be repaired, replaced or remanufactured at Manufacturer's option. No allowance will be made for shipping charges, damages, labor or other charges that may occur due to product failure, repair or replacement. This warranty does not apply to and there shall be no warranty for any material or product that has been disassembled without prior approval of Manufacturer, subjected to misuse, misapplication, neglect, alteration, accident or act of God; that has not been installed, operated or maintained in accordance with Manufacturer's installation instructions; that has been exposed to outside substances including but not limited to the following: sand, gravel, cement, mud, tar, hydrocarbons, hydrocarbon derivatives (oil, gasoline, solvents, etc.), or other abrasive or corrosive substances, wash towels or feminine sanitary products, etc. in all pumping applications. The warranty set out in the paragraph above is in lieu of all other warranties expressed or implied; and we do not authorize any representative or other person to assume for us any other liability in connection with our products. Contact Manufacturer at: 1-877-24PUMPS or [www.powerflopumps.com](http://www.powerflopumps.com), Attention: Customer Service Department, to obtain any needed repair or replacement of part(s) or additional information pertaining to our warranty.

**MANUFACTURER EXPRESSLY DISCLAIMS LIABILITY FOR SPECIAL, CONSEQUENTIAL OR INCIDENTAL DAMAGES OR BREACH OF EXPRESSED OR IMPLIED WARRANTY; AND ANY IMPLIED WARRANTY OF FITNESS FOR A PARTICULAR PURPOSE AND OF MERCHANTABILITY SHALL BE LIMITED TO THE DURATION OF THE EXPRESSED WARRANTY.**

Some states do not allow limitations on the duration of an implied warranty, so the above limitation may not apply to you. Some states do not allow the exclusion or limitation of incidental or consequential damages, so the above limitation or exclusion may not apply to you. This warranty gives you specific legal rights and you may also have other rights which vary from state to state.